

# BPA180-220 Instruction manual

Serial number: from 170001

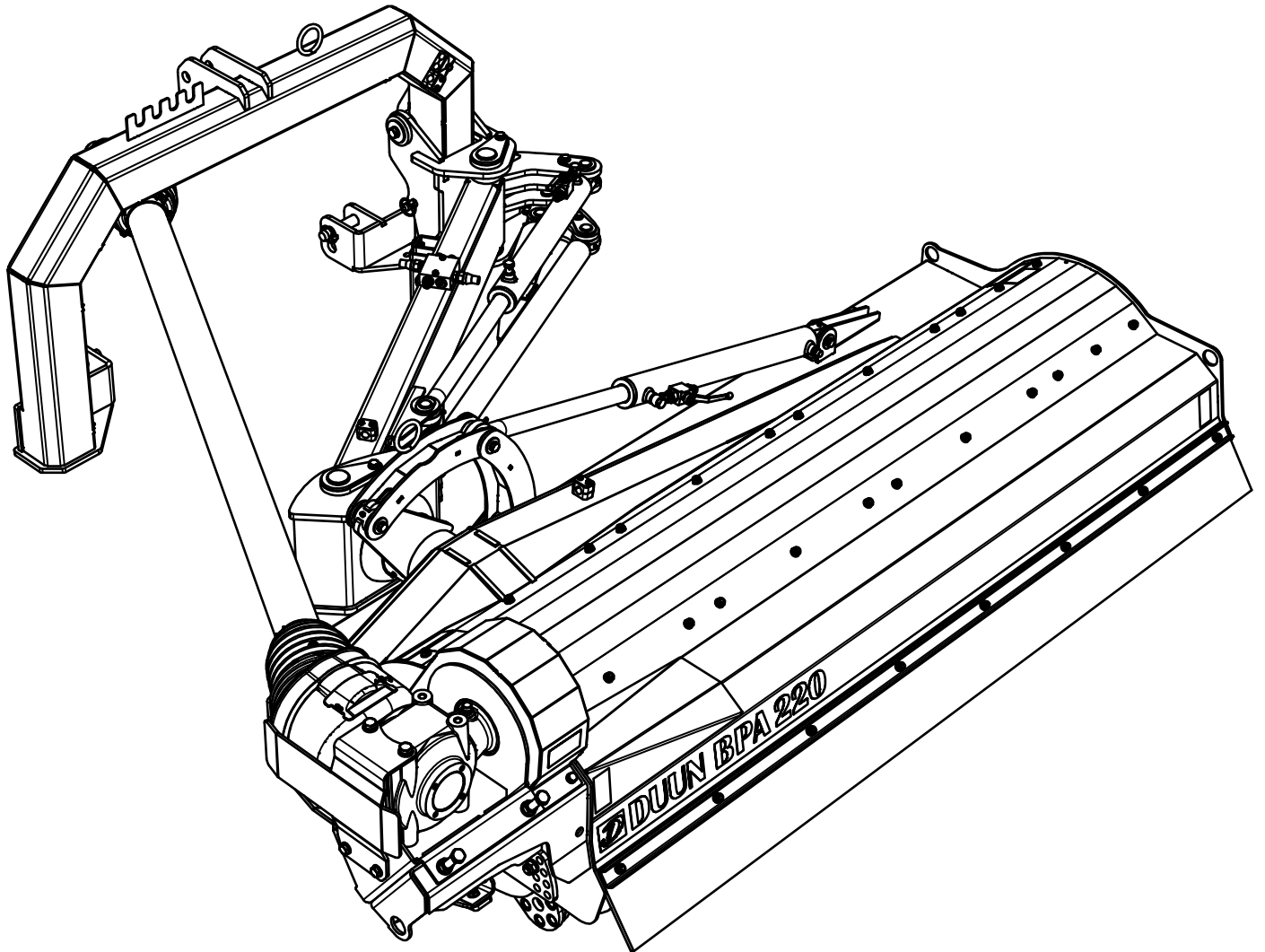

Congratulations on your Duun BPA180-220 mulcher.

All Duun tractor operated machines have been engineered and tested in close cooperation with representative users to produce functionally safe and user-friendly machines.

Please read this instruction manual before using the machine.

Good luck!

## Machine identification

Serial number and manufacturer are indicated on badge (A)

Register serial number and delivery time as indicated.

Always specify serial number when requesting service for the machine.

The machine is CE-marked (B), opposite side of drawing. This marking confirms that the machine has been manufactured in conformity with EU Directive Machinery.

---

Serial number

---

Time of delivery (month/year)

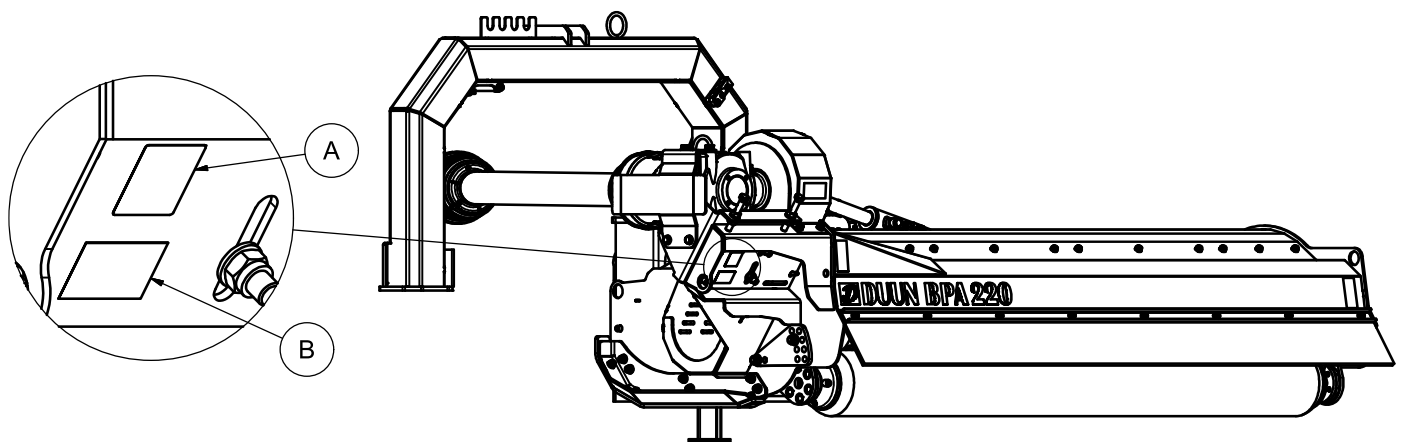





## CONTENT

MACHINE IDENTIFICATION	2
SAFETY	4
WARRANTY TERMS	7
TECHNICAL DATA	8
SPECIFICATIONS	10
PREPARATION FOR USE	11
CONNECTION	11
POWER TRANSMISSION SHAFT	11
HYDRAULIC HOSES	12
HYDRAULIC SECURITY	12
WORKING HEIGHT SETTING	12
HAMMER IRON	13
KNIVES AND RESISTANCE STEEL	13
GEARBOX	14
SERVICE AND MAINTENANCE	15
LUBRICATION INTERVAL AND GREASE QUALITY	16
BELT DRIVE	17
ADJUSTING AND REPLACEMENT OF BELTS	17
OPERATIONAL RISKS	18
PRACTICAL USE	18
DISCONNECTION	18
DECLARATION OF CONFORMITY	19
DECLARATION OF CONFORMITY	20

# SAFETY

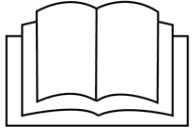
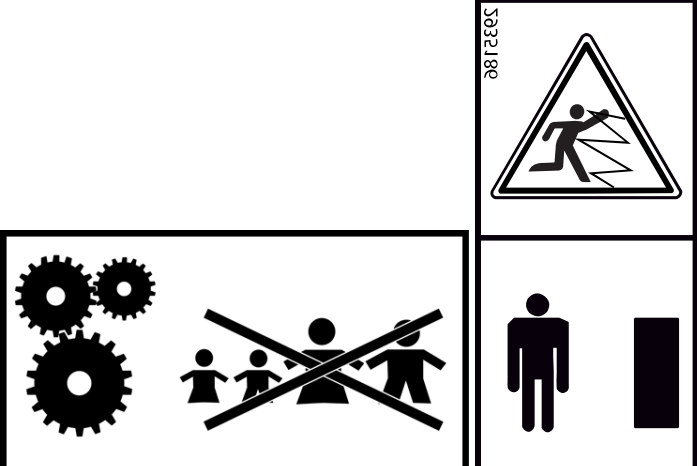
All operators, mechanics and the owner must always work carefully with agricultural machinery. Read and observe safety instructions in this instruction manual.

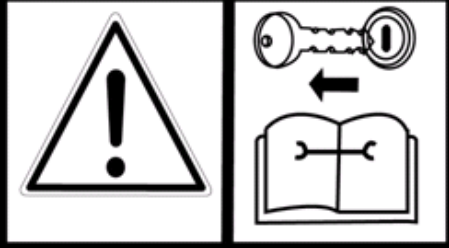
	<p>Be particularly aware of warning signs with this symbol, it marks measures that must be carried out in order to avoid accidents. The symbol appears in the instruction manual and on warning signs on the machine.</p>
  <p style="text-align: right;">2935064</p>	<p><b>Instruction manual</b> All operators, mechanics and the owner must be well acquainted with the instruction in this instruction manual before the machine is taken into use.</p>
 <p style="text-align: right;">5032180</p>	<p><b>Safety of the surroundings</b> Be very careful when other people or animals are near the machine or tractor. Never start the machine when there are people or animals close to it, also never stand between the tractor wheels and the machine!</p>
 <p style="text-align: right;">2935069</p>	<p><b>Safe connection and use</b> Do not allow anyone to stay between the machine and the tractor when the machine is connected to the tractor. The same applies during the use of the machine. Make sure that the connection is carried out in a safe manner. By automatically connecting with a triangle or HMV, the hydraulic hoses are connected before the start of work. Connecting with draw bolts, secure the drawbar connection with lunch pins before the hydraulic connection and start operation.</p>
	<p><b>Safety in case of interruptions and maintenance</b> Remember always to stop the tractor's engine and remove the ignition key before you lubricate, adjust, clean, or carry out repairs. This is to secure that the tractor does not start before you have completed the operation.</p>



**Power transmission shaft**

The tractor is disengaged and the handbrake is applied before the shaft is connected to the tractor's PTO.

The drive shafts are always to be equipped with original protection covers.

**Damaged and worn covers are to be replaced immediately!**

Make sure that all covers for the shaft are in good condition and correctly fitted. Never start the machine when this is not in order. The locking chains for the plastic covers are always to be fixed to the appropriate brackets in order to prevent the covers to rotate. The covers must be lubricated according to the specified interval.



**Rotating parts – high risk of injury**

The rotating parts of the machine can cause major damage to body parts that come into contact with them. Do not allow anybody to stay in the work area when a machine is in operation.

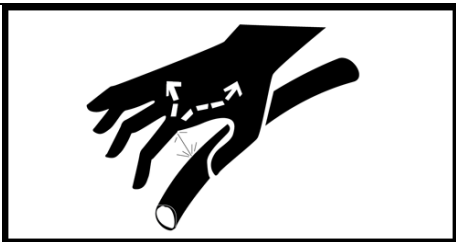

**Hydraulic high fluid pressure**

Be careful when you work with hydraulics. Wear eye protection and gloves. Hydraulic oil under high pressure may penetrate the skin and cause serious infections. See a doctor if you have sustained an injury. Make sure no one is close by when performing hydraulic functions.

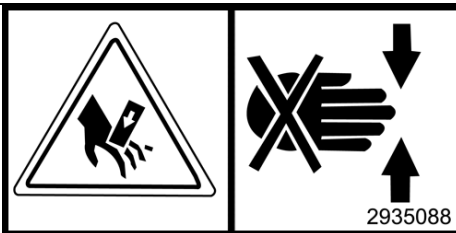

**Rotating parts – risk of crushing**

Case covers and moving parts are preferably marked in yellow.



All covers must always be used except when necessary maintenance, and always with a stopped engine as mentioned in **safety in case of interruptions and maintenance**. Pay special attention to clamping risk at points marked for this. Avoid hydraulic movement of the ejection spout when there are people nearby.

**Never drive with open covers for chains and sprockets. Chains and sprockets can cause major damage to body parts that come into contact with them during the operation.**

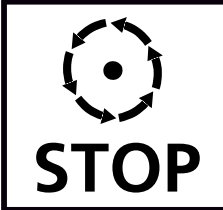

**Risk of crushing when adjusting the working height**

When adjusting the working height, ensure that you do not get trapped under the machine.

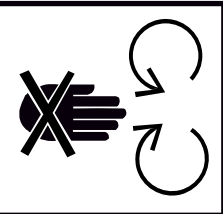
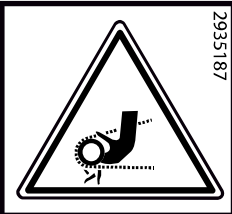
		<p><b>Rotating parts – risk of crushing</b> The machine's gearbox has a release which causes the blades to rotate after the PTO is turned off.</p>
		<p><b>Clamping risk of belt drive</b> Never remove the belt drive safety cover while the machine is running. Stop the tractor and remove key before removing the cover.</p>

Always lower the machine to safety rest at ground level when it needs to be parked.

Working on the machine the tractor engine must be stopped and the power shaft set to neutral.

The gearbox on the machine has a freewheel hub which means that the machine's rotor is in motion after the PTO is disconnected. Make sure the rotor has stopped before starting work on the machine.

Never work under a raised device unless it is mechanically secured against falling down.

Before startup after servicing make sure all tools have been removed and brought into place.

Do not work in clothing that can be retracted into moving parts of the machine (e.g. scarves, wide coats).

Wear hearing protection if the machine has annoying or damaging noise levels.

Before the machine is raised or lowered, make sure that no person is near or touching the machine.

**If warning signs are removed during repairs or service, new signs should be installed immediately!**

## Warranty terms

Duun mulcher has 12 months guarantee against defects in materials and workmanship.

Parts that are not originally produced by Duun Industrier as, e.g. hammer knives, hydraulic parts etc. are subject to these suppliers' guarantees and terms.

In cases where a repair is considered to be covered by the guarantee, the representative must inform the supplier's representatives that the repair is intended executed based on the guarantee. In this context, the following information must be recorded:

- Product name
- The product's serial no. (see the machine identification)
- Date of sale
- The product owner's address, telephone no.

In case of such a repair, the supplier is presented with a claim within 3 weeks after the repair date.

Replaced parts are to be kept until a decision has been made with reference to the claim and the replaced parts are to be forwarded to Duun Industrier as for assessment if so required.

As the employment of the product is beyond our control, we may only guarantee the quality and do not accept liability for the product's general performance.

Duun Industrier as reserves the right to modify the design and specifications and/or make alterations and improvements without notification.

What is not included in the guarantee:

- The guarantee does not cover economic loss as a consequence of interruptions.
- The guarantee does not cover consequential loss due to defects.
- The guarantee does not cover defects or damage caused by misuse and uses that are not in accordance with the instruction manual's specifications and guidelines.

# Technical data

BPA180-220

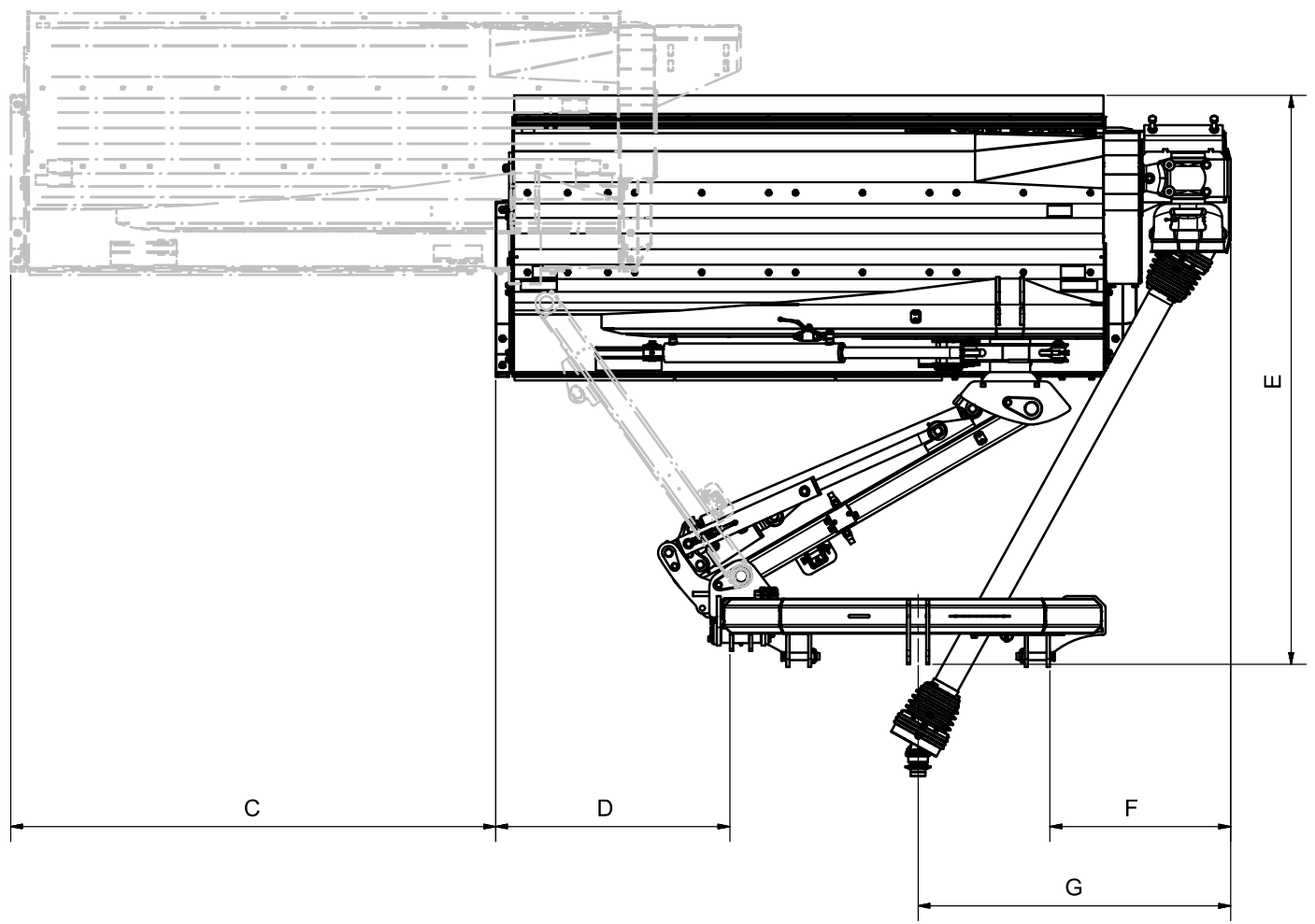
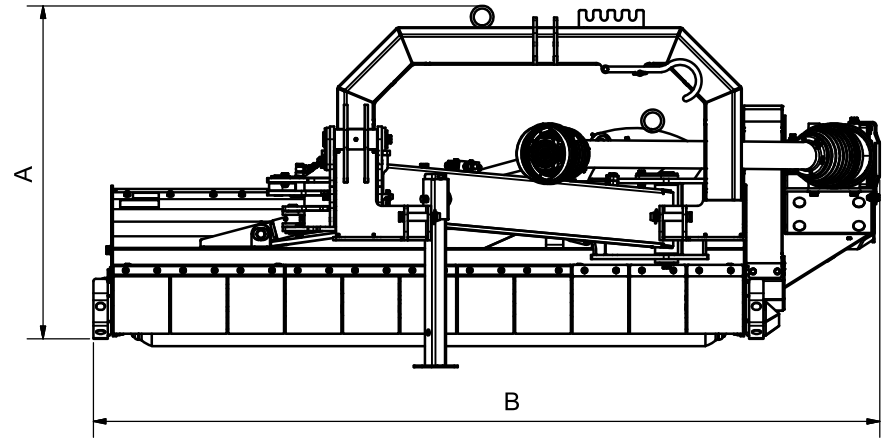



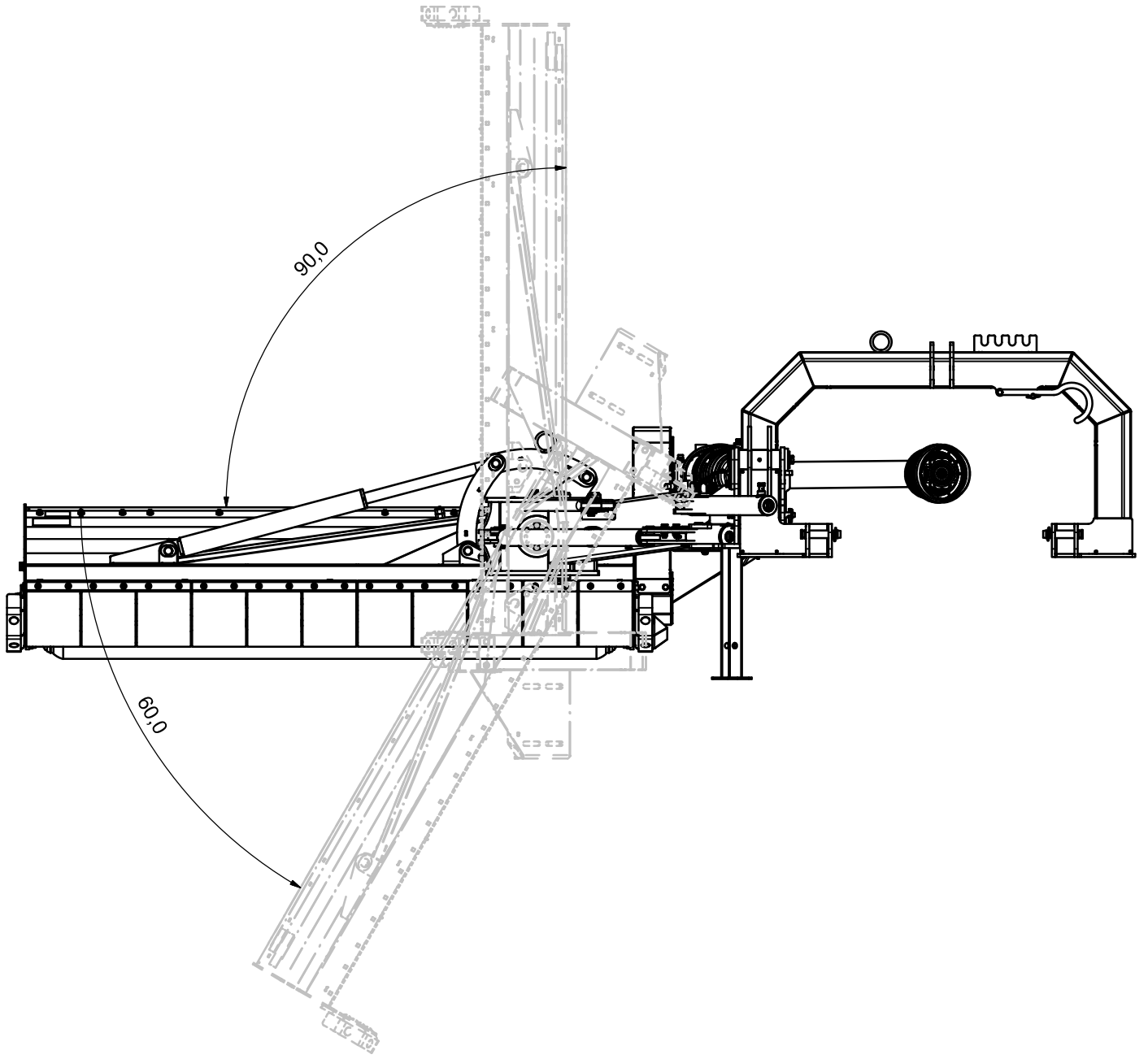

## Specifications

	<b>BPA180</b>	<b>BPA220</b>
Width (mm)	1800	2200
<b>A</b> (mm)	1160	1160
<b>B</b> (mm)	2341	2741
<b>C</b> (mm)	1810	1810
<b>D</b> (mm)	474	874
<b>E</b> (mm)	2122	2122
<b>F</b> (mm)	674	674
<b>G</b> (mm)	1166	1166
Weight kg	780	840
Weight of PTO shaft wide angle both sides kg	42	42
Rotor speed of pto 540 o/min	2053	1943
Required effect kW/hk	50	55
Minimum tractor weight kg	3200	3500
Freewheel	Built in gearbox	
SPX belts for rotor drive	4	4
Outside diameter rotor (mm)	41,5	41,5
Diameter rotor x wall thickness (mm)	168,7x8	168,7x8
Speed of impact (m/s) pto 540	45	45
Number of hammers	16	18
Diameter of roller (mm)	193,7x5	193,7x5
Belt tensioning	Mechanical	

## Asseccories

Chain in the front for better protection against mulcher splashes.

127209007            Protection chain BPA222  
 127219007            Protection chain BPA180

## Preparation for use

Before using a mulcher, following points must be checked:

- Gearbox oil level.
- All safety signs must be readable.
- All screws and bolts must be tight.
- All lubrication points must be lubricated. Lack of lubrication leads to a risk of breakdown. Also, be careful not to "over-lubricate" the bearings, as this entails the risk of heat build-up and overheating in the bearing itself. In the case of too little lubrication, water can penetrate (infiltrate) the bearings.

## Connection

***Stabilization struts/support struts on tractors must be used.***

***This is to ensure that the mulcher does not get uncontrolled lateral movements while driving – goes in the same direction as the tractor all the time.***

Make sure no one is standing between the tractor and the machine during connection. Back the tractor up to the mulcher and stop the engine before the lifting arms are mounted in the three-point linkage.

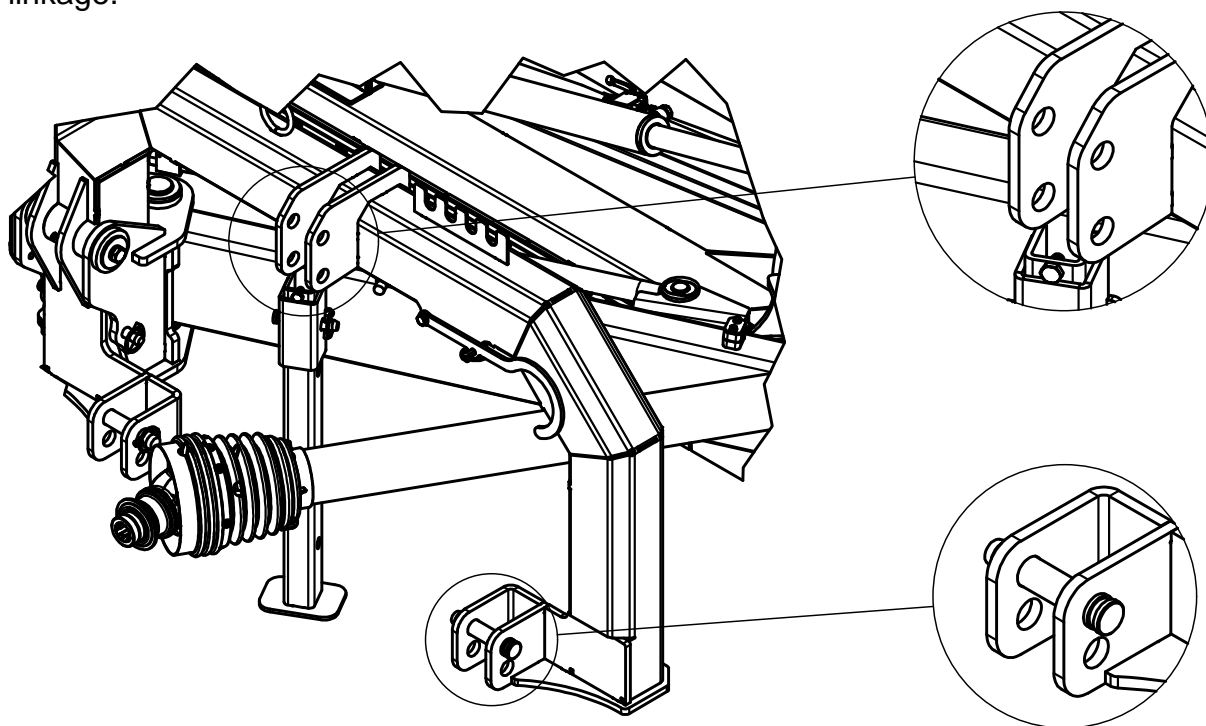

## Power transmission shaft

Make sure that the shaft's protective tubes are undamaged and that two halves of the shaft fit freely into each other. Make sure the pto shaft has enough length. Any cutting of the shaft is carried out according to the instructions for this. The cutting area is chamfered inside and outside, and the profile pipes are lubricated. Too small telescopic length on the shaft entails a risk of overloading the tractor's pto and mulcher's gearbox. **On the other hand, the shaft must not be too long so that it presses on the front and rear bearings and destroys them.** It is important to consider all the positions that the mulcher achieves when pushing to the side, raising and lowering tractor arms and using the top braces.

Please lubricate the power transmission shaft before use.

The locking chains for the protective covers must always be attached to suitable attachments to prevent the covers from rotating.

The power transmission shaft is maintained and used in accordance with the enclosed instruction manual. Make sure that the protective covers for the power transmission shaft are undamaged, and replace them if they are damaged.

## Hydraulic hoses

There are three hydraulic hoses that are connected to the side shift and tilt of the mulcher. They are connected to the tipping outlet on the tractor.

Check connections of the hose, that they are not stretched or cut during use. Tighten loose hose connections and secure/fasten the advance of the fasteners.

Lack of securing of hydraulic hoses can lead to leaks and consequential damage to the tractor and components.

Check that all hoses are tight and undamaged before starting hydraulic functions. Pay special attention to the dangers of hydraulic oil under pressure.

## Hydraulic security

The mulcher is equipped with a hydraulic safety device (A) which is intended to prevent damage in situation of getting stuck in obstacles such as trees, stumps, stones and similar things. The mulcher will move away from obstacles if the pressure becomes too high and will be returned to position by raising cutting unit.

NB! The fuse is not a guarantee that the mulcher will not be damaged, but a small buffer that allows the driver to stop when encountering obstacles.

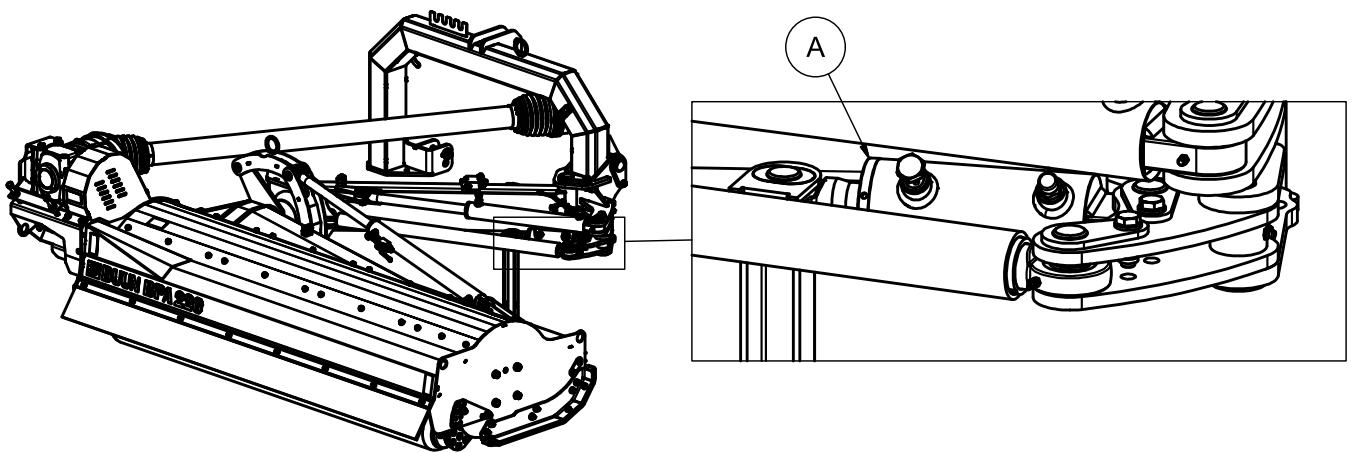

## Working height settings

The working height of the mulcher is regulated by changing the height of the support roller. This is done with the adjustment screws in point (A). The upper strut is used to adjust the height of the cut relative to the support roller. A long top brace gives a long cutting length and a short top brace gives a short cutting length. Skid pads help to keep the cutting length correct in hilly terrain.

The bolt marked (B) is for locking the floating function between the three point and the linkage.

This must be removed and placed in the storage hole (C) during use of the mulcher. This is because the mulcher will follow the terrain better. Parking the mulcher, the bolt must be returned to the locked position (B).

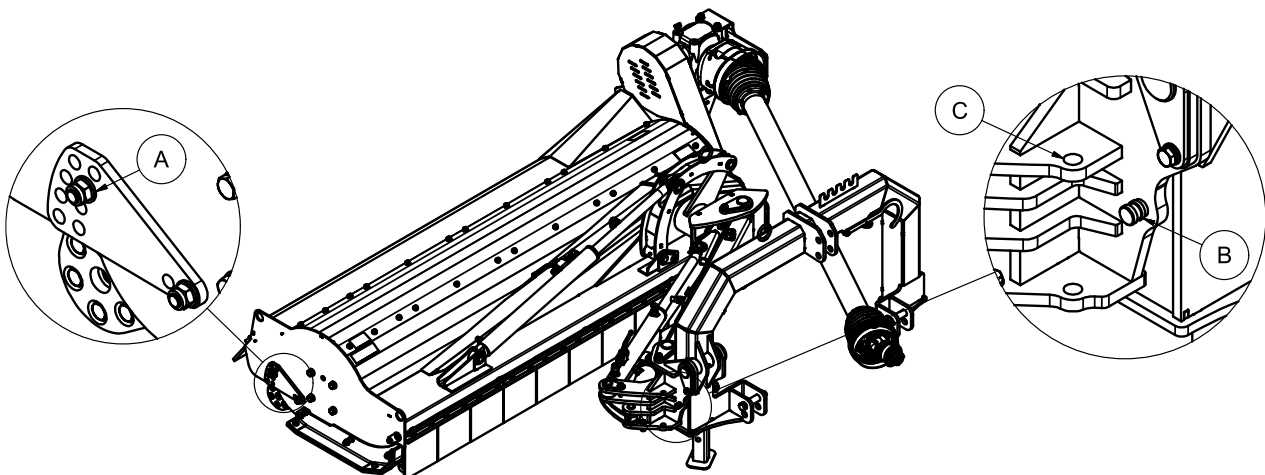

## Hammer iron

The hammer iron of the mulcher must be checked before each time the machine is used. Make sure that all hammer irons are in places and that the fixing bolts are properly tightened. The mulcher should never be used if it is missing one or more hammer irons. Safe and efficient use of the mulcher depends on regular checks and maintenance of the hammer irons, fastening bolts and fastening brackets on the rotor.

## Knives and resistance steel

The mulcher has blades fitted as standard. They have function of cutting up materials such as twigs and timber better. You can pick out these knives and run mulcher without them.

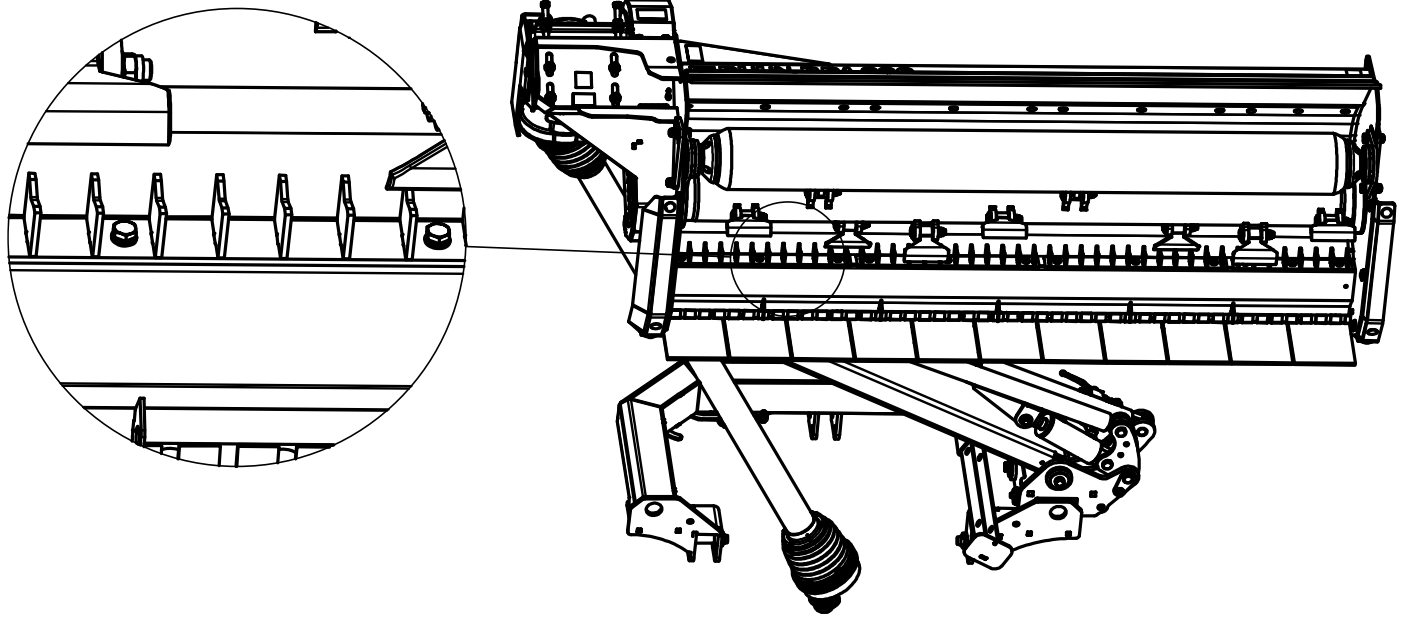

## Gearbox

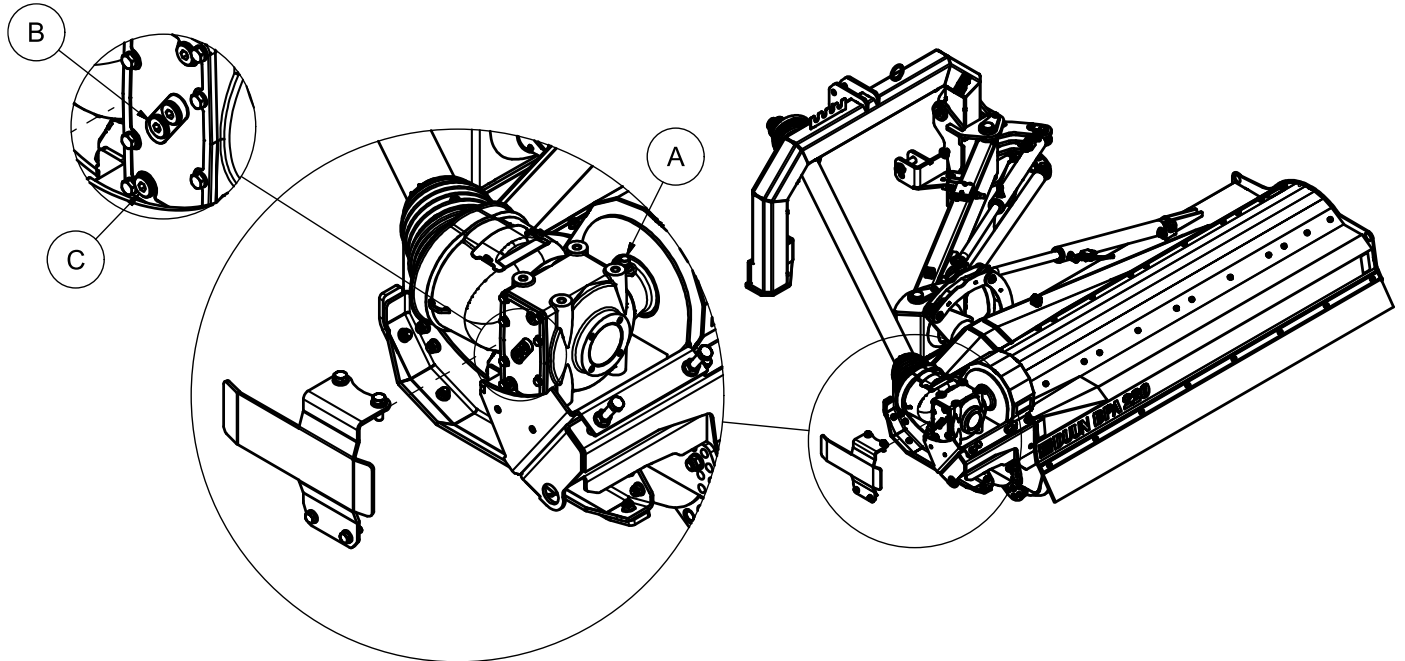

Recommended oil: Gearbox oil Mereta 150 or Mereta 220 synthetic oil (Statoil) or Esso Syntetic EP150.

Other oil must fit the standard SAE90EP or GL5.

Mereta 220 - 1 l. has item no. 531 0 110

Check the oil level after 50 operating hours or after each season by loosening the screw marked B, as illustrated in the sketch (oil should leak out at a sufficient level).

If the oil level requires refilling, refill with the same type of oil.

The first oil change is recommended after 50 hours of use, and then every second season or after 500 operating hours – if 500 operating hours occur before the end of the 2nd season, oil change with Mereta 220 is carried out as recommend.

It is an advisable to change the oil when the gearbox is warm.

- A- Air plug / filler plug
- B- Oil level plug
- C- Drain plug

**It is very important to fill the gearbox with the correct amount of oil.  
Too much oil will lead to a higher operating temperature and risk of breakdown.**

## Service and maintenance

Before cleaning, lubricating, repairing or adjusting the machine, stop the engine and activate the handbrake, and remove the key during work.

Pay special attention to safety during maintenance work, park the machine in according with specified safety rules.

### Inspection after screw connections

Screws - nuts - fittings and bolts on the machine should be re-tensioned after two hours of operation. All moving parts should be lubricated with grease.

Hammer blades, mounting bolts and skid pads are exposed to heavy wear - check and replace or sharpen hammer blades before damaging the housing itself and mounting brackets. Never use the machine if it vibrates or is not balanced.

To extend the life of the machine, it is recommended to clean it after use.

Do not pour water directly into the bearing. For long-term storage, it is recommended to lubricate the machine with acid-free oil.

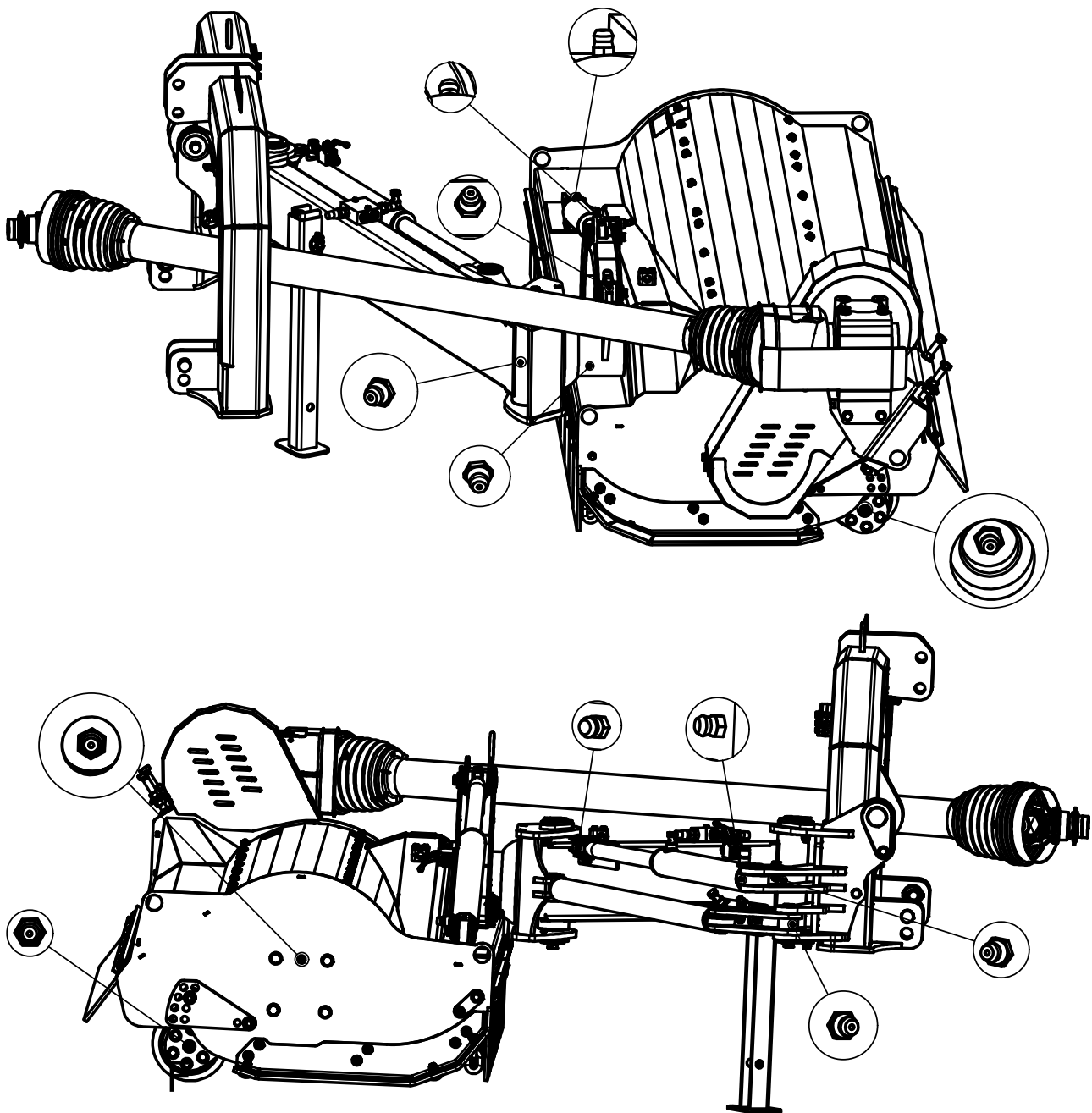

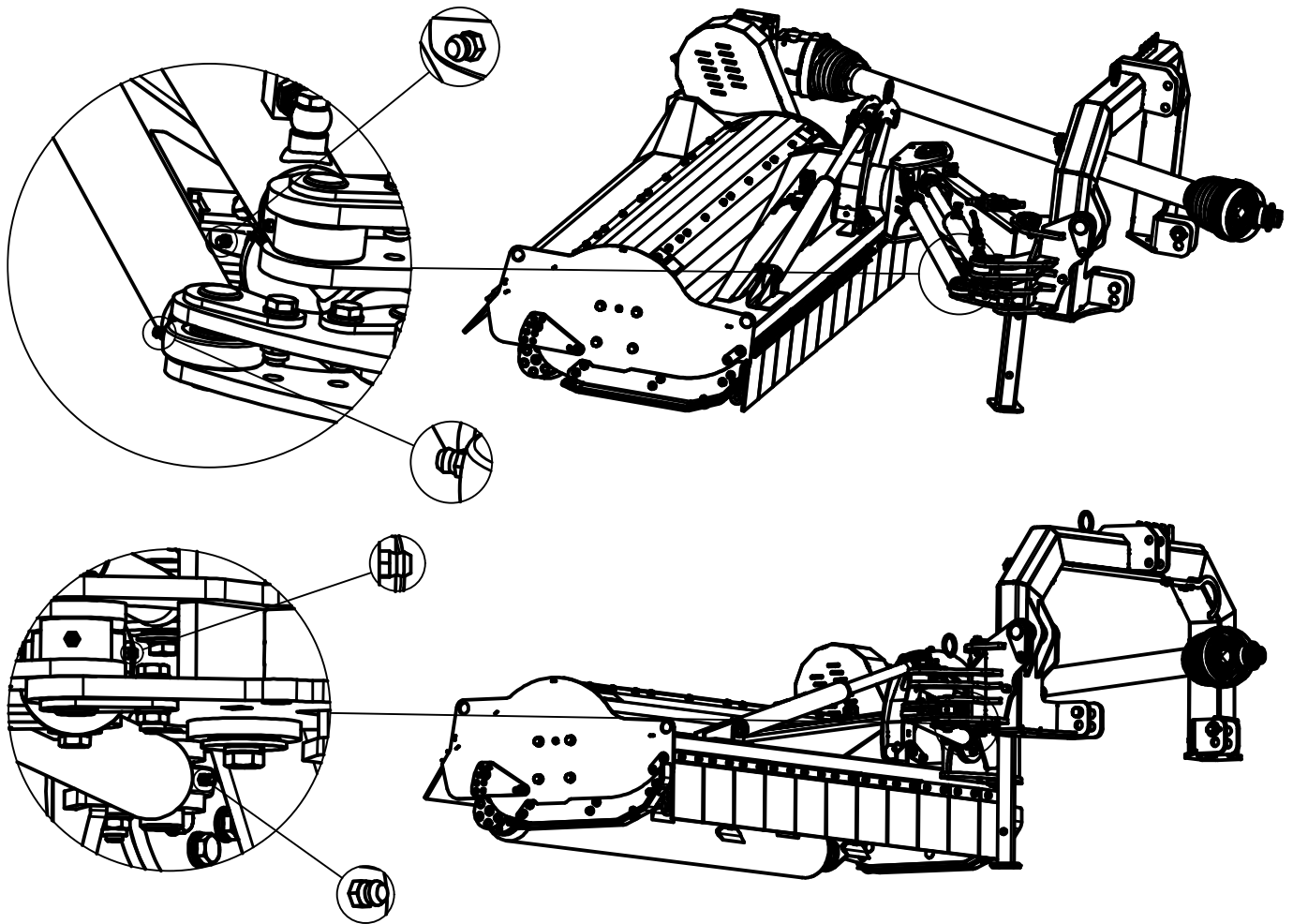

**Interval of lubrication and grease quality**

**Rotor**

Interval      Every 300 operating hours or once a year. Always lubricate before storage. It is loaded with grease from the factory and should be approx. 10 grams of fat per serving.

**Roller**

Interval      Every 300 operating hours or once a year. Always lubricate before storage. It is loaded with grease from the factory and should be approx. 10 grams of fat per serving.

**Bearings on lifting arm and cylinders**

Interval      Every 50 operating hours. Always lubricate before storage.

**Power transmission shaft – universal joint + telescopic tube**

Interval      Every 8 - 10 operating hours.

Maintained according to the attached instruction book. Please contact the supplier if this is missing.

Grease quality: Universal grease of good quality.

The side shift on the three-point linkage can be lubricated with thin oil if necessary.



## Belt drive

The drive belts must be checked/adjusted after the first 5 working hours, then they are adjusted every 30 hours. The belts are checked by pressing them through the inspection hatch (A) with a screwdriver. Straps must be able to press in 10mm.

If the belts are damaged or worn, all belts must be replaced at the same time, even if one or more of them look perfectly fine. This is to ensure that there is even tension.

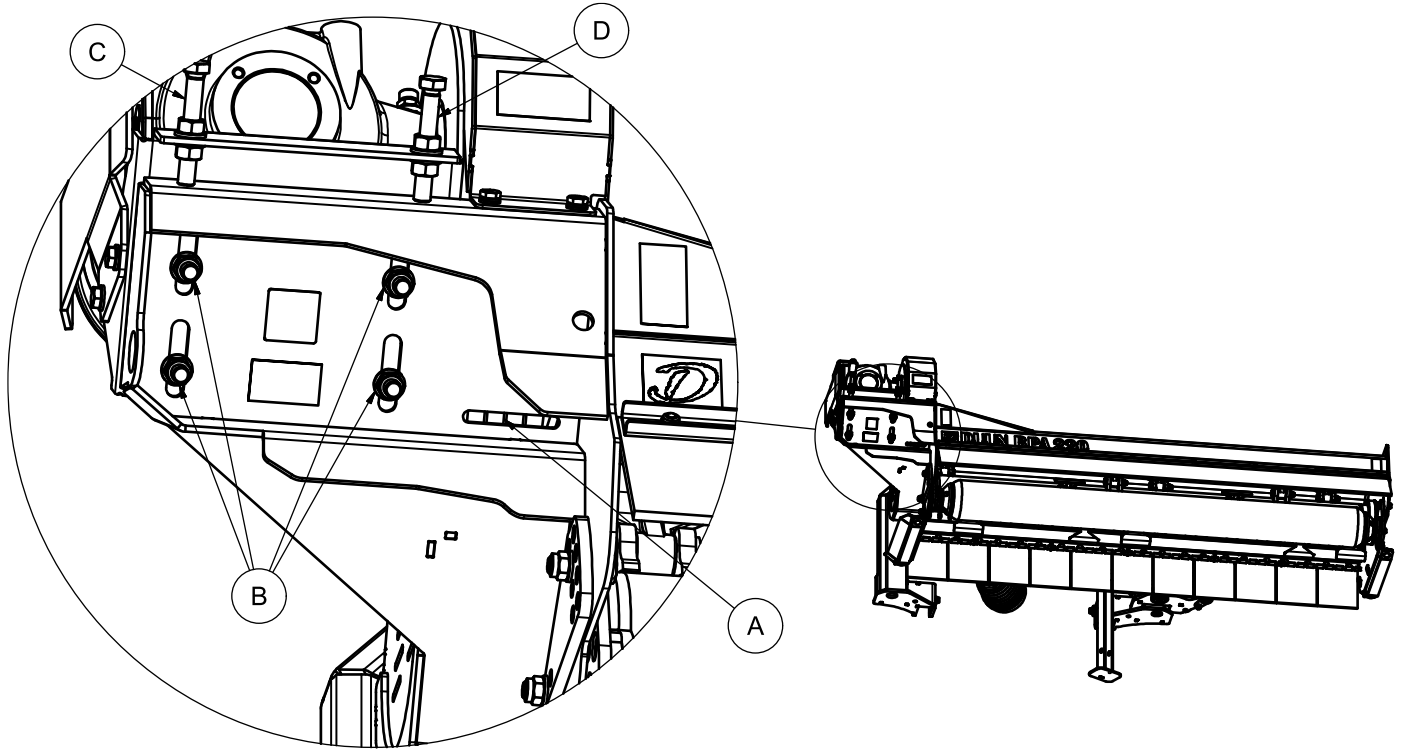

## Adjusting and replacement of belts

Belts are adjusted by unscrewing four screws marked (A).

Tighten belts by adjusting the tension screws marked (B) and (C). For the pulleys to line up, it is important that the tensioning screw (B) is adjusted synchronously with the tensioning screw (C). A straight edge can also be placed on the pulleys to check that they are aligned correctly with each other. When the belts have the correct tension, fasten the screws marked (A).

The same procedure is used for belt replacement.

## Operational risks

It is the driver's responsibility not to expose himself or others to danger during the use of the mulcher. Attention should be paid to people and animals located near the machine. Since there are other objects on the ground (stones and similar things), the driver of the mulcher must always take into account that other objects can fly out of the machine and damage the environment. No one should ever stand on the machine while it is driving or moving. Protective covers must always be on when it is used. During transport, the hydraulic system taps (see illustration at the bottom of the page) must be closed.

## Practical use

The Norwegian Labor Inspection Authority has listed mulchers among machines that must be used with particular care and must therefore not be operated by people without documented training. The user must have a driving license for a tractor (aged 16) and have a certificate that he has received training in the use of the machine/tool.

The machine requires skilled operation, the user manual must be read before connecting to the tractor and putting it into operation, even if the user had previous experience with a similar machine – this is for user's safety.

The maximum speed of the PTO is 540 rpm.

The direct-coupled PTO must not be switched on at high rpm.

Do not use the machine if it is not working properly. Do not drive if one or more blades are missing.

## Disconnection

This happens in the reverse order of connection.

The tractor's PTO must be disconnected when working with the machine and the PTO shaft. Place the machine on the even ground.

The taps shown in the illustration are closed so that the mulcher will stand firmly when disconnected.

Disconnect hydraulic hoses.

Disconnect the power transmission shaft and hang it on a hook attachment.

Locking bolts for drawbars are released.

The machine is now disconnected and can be left.

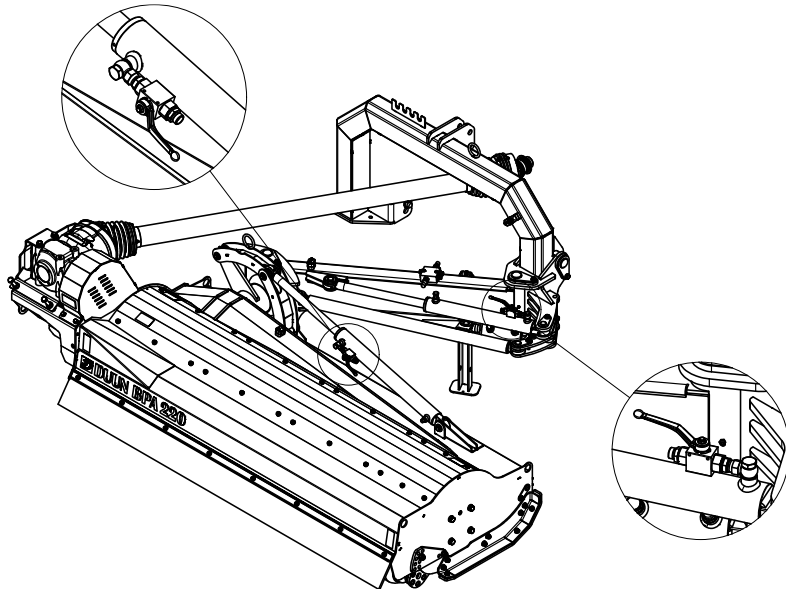

## Declaration of conformity

### Responsible person

Name: Karl Martin Eggen  
Position: CEO  
Company name: Duun Industrier as  
Address: N-7630 Åsen  
Norway  
Telephone: +47 74 01 59 00

Person responsible for the technical documentation: Rolf Even Duun

Declares that the following machine: BPA180 Mulcher  
Manufacturer: Duun Industrier as  
Type: Duun Mulcher BPA180  
is in accordance with:

Directive 2006/42/EC Machinery

Signed by:



---

Karl Martin Eggen

Åsen, 15.09.2020

## Declaration of conformity

### Responsible person

Name: Karl Martin Eggen  
Position: CEO  
Company name: Duun Industrier as  
Address: N-7630 Åsen  
Norway  
Telephone: +47 74 01 59 00

Person responsible for the technical documentation: Rolf Even Duun

Declares that the following machine: BPA220 Mulcher  
Manufacturer: Duun Industrier as  
Type: Duun Mulcher BPA220  
is in accordance with:

Directive 2006/42/EC Machinery

Signed by:



---

Karl Martin Eggen

Åsen, 15.09.2020